

NOTES:

- 1) ALL PRECAST SECTIONS SHALL CONFORM TO THE REQUIREMENTS OF ASTM-C-478.
- 2) ALL POURED IN PLACE CONCRETE SHALL HAVE A 28 DAY STRENGTH OF 3,000 P.S.I. .
- 3) FOR LOCATIONS OUTSIDE OF PAVED, OR OTHER HARD SURFACED AREAS, MANHOLE RIM ELEVATION SHALL BE BETWEEN 6" AND 12" ABOVE ADJACENT FINISHED GROUND ELEVATION.
- 4) SEE L.O. SPECIAL PROVISIONS FOR TRACER WIRE DETAILS.

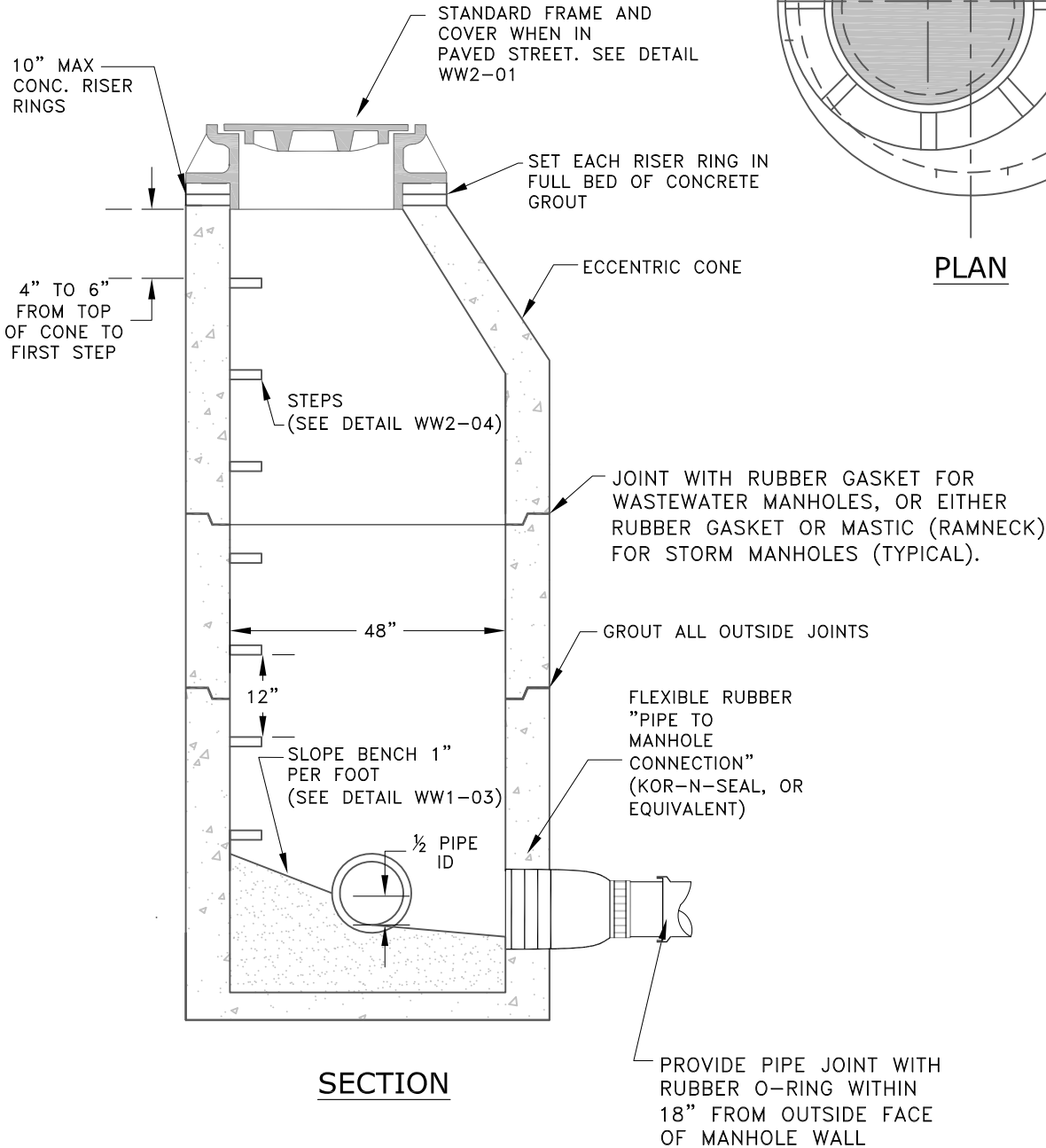
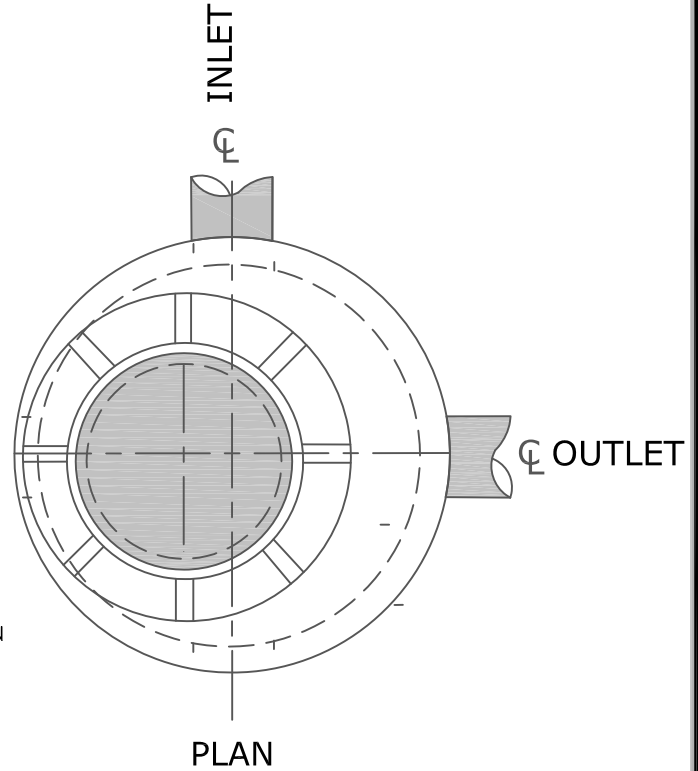

City of Lake Oswego
Engineering Division

Erica Rooney, P.E. City Engineer

STANDARD MANHOLE

WW1-02

EFFECTIVE DATE: JANUARY 1, 2018

NOT TO SCALE

DRAWING NUMBER